

**TOORX**  
FITNESS IN MOTION

# INSTRUCTION

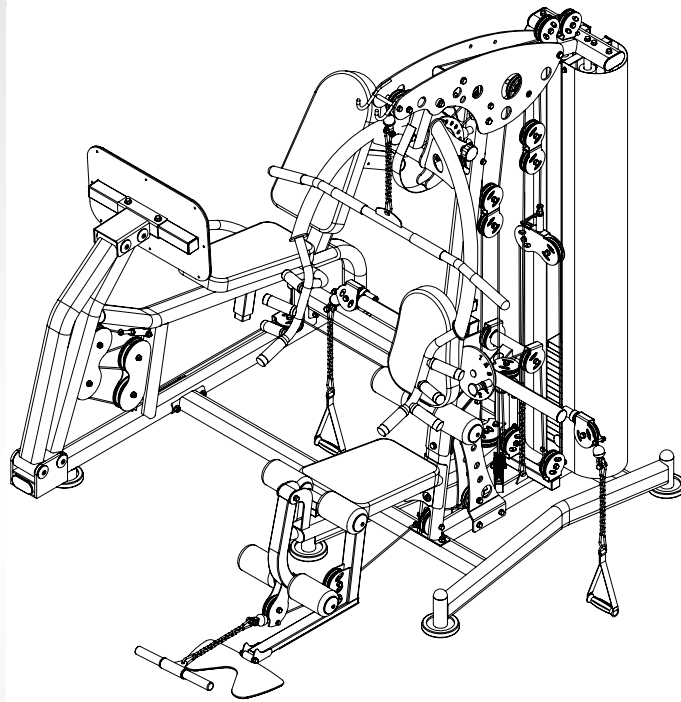

## LEG PRESS MSX3000



Cod : GRLDTOORXLGPRESS

Rev : 00

Ed: 10/18

# Table of Contents

Spare parts list .....	3
Spare parts list .....	4
Spare parts drawing .....	5
Fasteners drawing .....	6
Assembly step (1) .....	7-8
Assembly step (2) .....	9-10
Assembly step (3) .....	11-12
Assembly step (4) .....	13-15
Assembly step (5) .....	16-17
Assembly step (6) .....	18-19
Explosion drawing .....	20
Factory assembly explosion drawing.....	21-23

## Spare parts list

No.	Description	Note	Qty.
5	washer	Φ10	19
11	lock nut	M8	2
15	washer	Φ8	13
18	locking spring knob	Φ10	2
20	washer	Φ12	14
21	lock nut	M12	6
23	lock nut	M10	9
30	hexagon bolt	M10*25	2
35	big washer	Φ25*10*2.0	4
52	hexagon bolt	M10*45	1
55	pulley	Φ95*26	1
65	hexagon bolt	M10*75	2
72	spring washer	Φ8	8
89	foot margin cover	Φ120	2
92	oval tube plug	50-100	2
97	reduction sleeve	□50-40L	1
99	hexagon socket button head bolt	M8*16	1
100	inner plug	□25*50	2
125	leg press main frame		1
126	leg press front connection tube		1
127	leg press back connection tube		1
128	connection plate		1
129	arc-shaped connection plate		2
130	spring washer	Φ12	2
131	hexagon bolt	M12*30	2
132	hexagon bolt	M12*80	2
133	hexagon bolt	M12*125	4
134	leg press support tube-1		1
135	leg press support tube-2		1
136	shaft	Φ25*125	2
137	plug		8
138	hexagon socket button head bolt	M10*25	8
139	shaft	Φ25*125	2

## Spare parts list

No.	Description	Note	Qty.
140	support tube		1
141	footplate tube		1
142	hexagon bolt	M10*50	4
143	big pulley	Φ127*28	4
144	leg press cable	L:3255mm	1
145	hexagon bolt	M8*20	8
146	hexagon bolt	M8*70	2
147	leg press seat cushion adjust frame		1
148	leg press seat cushion		1
149	leg press handle		1
150	hexagon bolt	M8*25	1
151	leg press back cushion adjust frame		1
152	leg press back cushion		1
153	oval reduction sleeve	50-100	1
154	cone rubber cushion	Φ42*Φ32*26	1
155	sq plug	□50*50*2.0	2
156	"+"slotted countersunk head bolt	M6*10	8
157	footplate		1
158	bearing	6005	8
159	handle grip	Φ25	2
160	handle	Φ40*Φ25*29	2
161	"-"slotted headless bolt	M4*5	2
162	hexagon bolt	M10*40	1
163	cable adjust sleeve		1

# Spare parts drawing

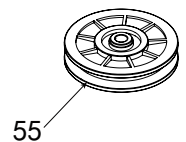
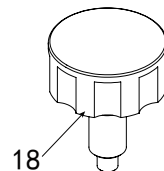
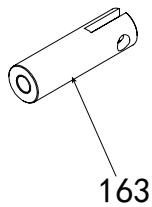
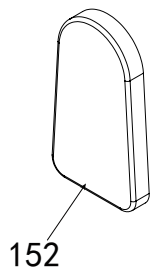
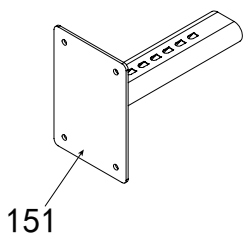
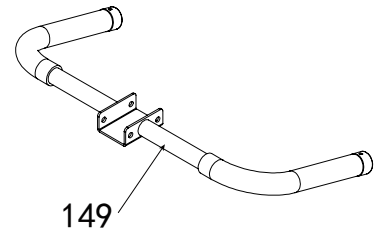
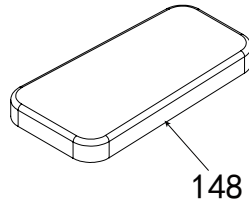
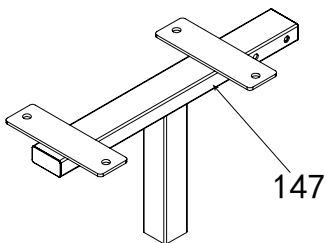
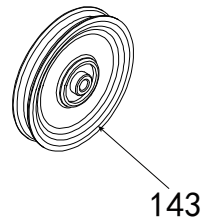
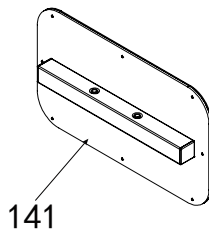
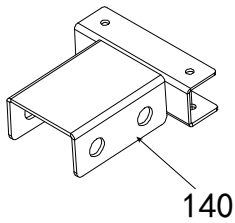
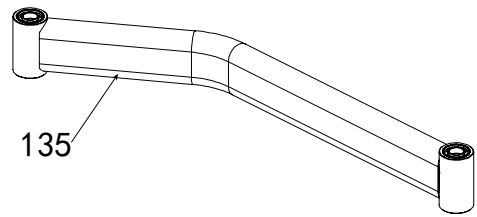
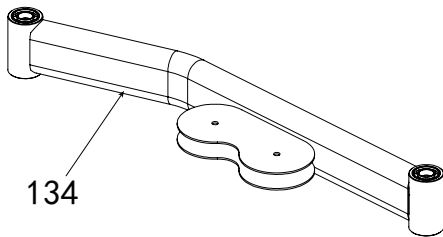
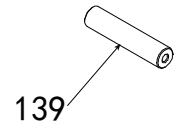
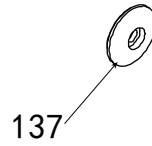
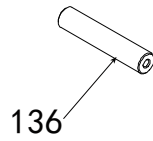
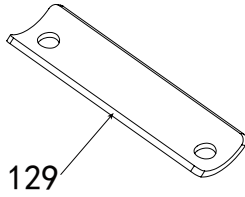
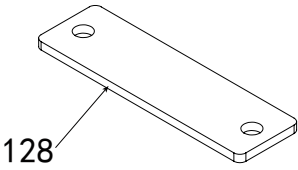
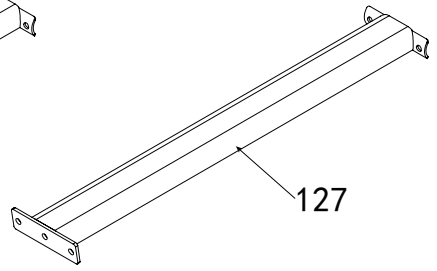
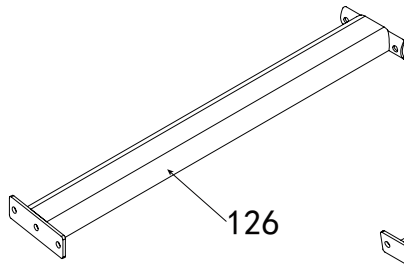
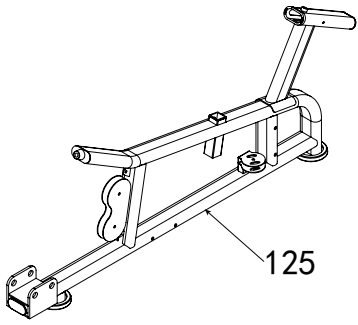

## Cable drawing

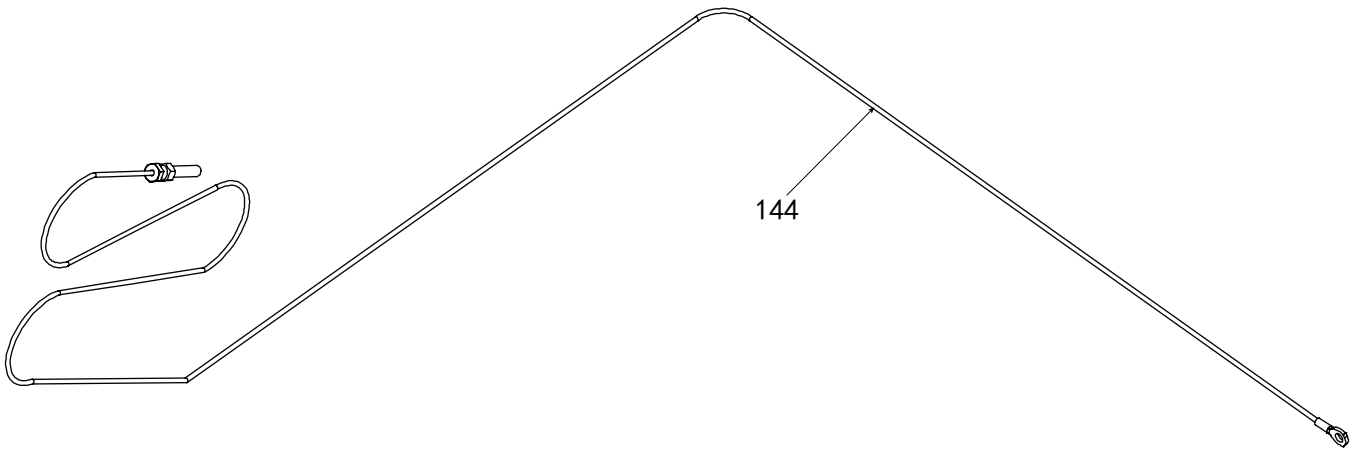

## Fasteners drawing

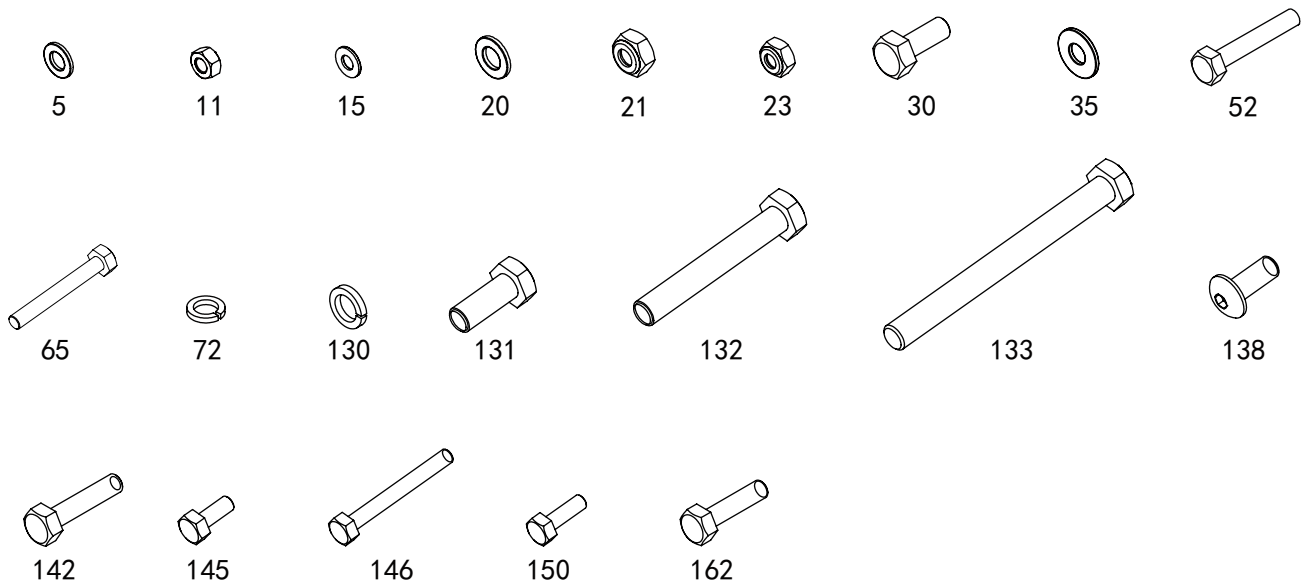

## Bolt length measurement ruler



## Assembly step (1) explosion drawing

No.	Description	Note	Qty.
20	washer	Φ12	14
21	lock nut	M12	6
125	leg press main frame		1
126	leg press front connection tube		1
127	leg press back connection tube		1
128	connection plate		1
129	arc-shaped connection plate		2
130	spring washer	Φ12	2
131	hexagon bolt	M12*30	2
132	hexagon bolt	M12*80	2
133	hexagon bolt	M12*125	4

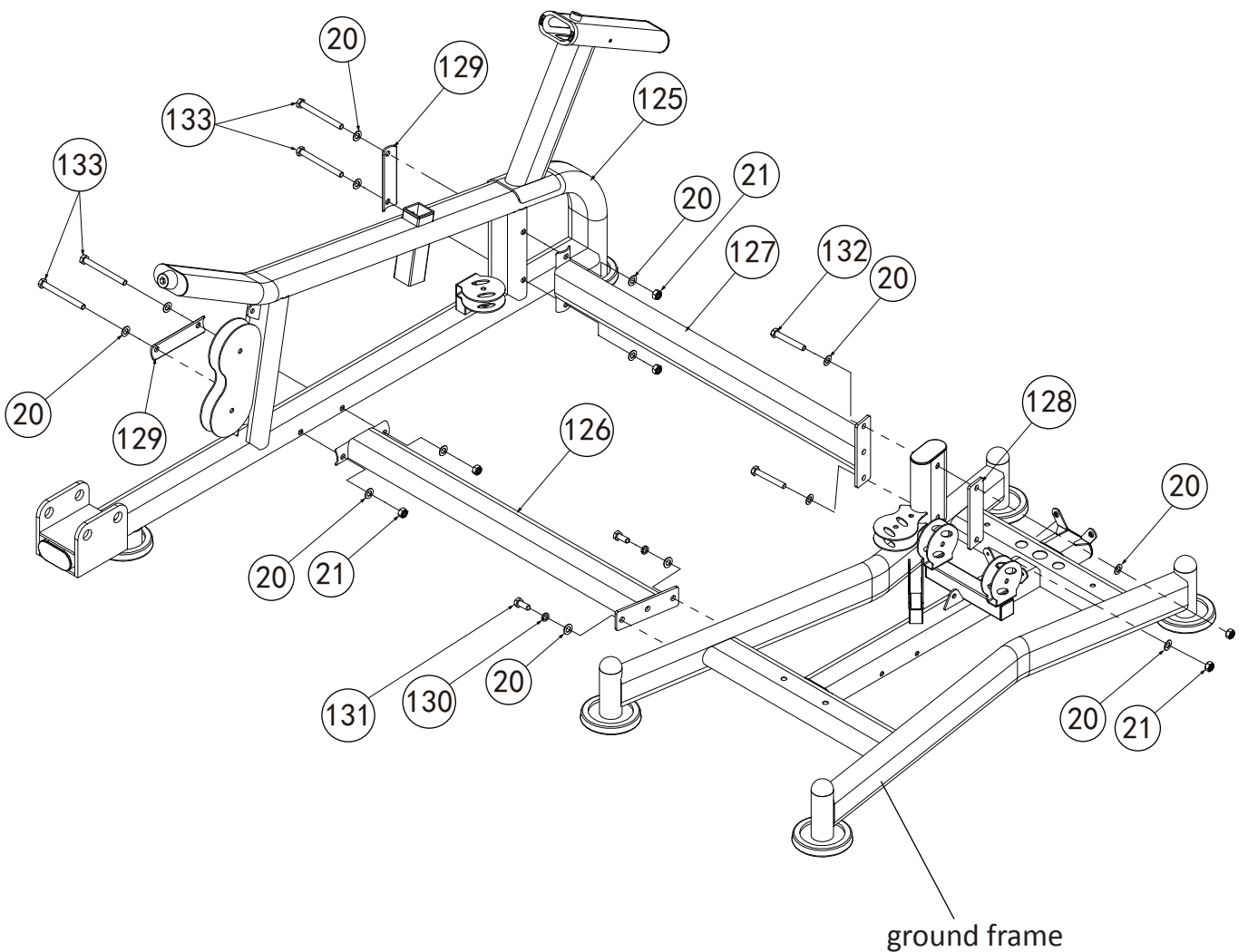

## Assembly step (1) drawing

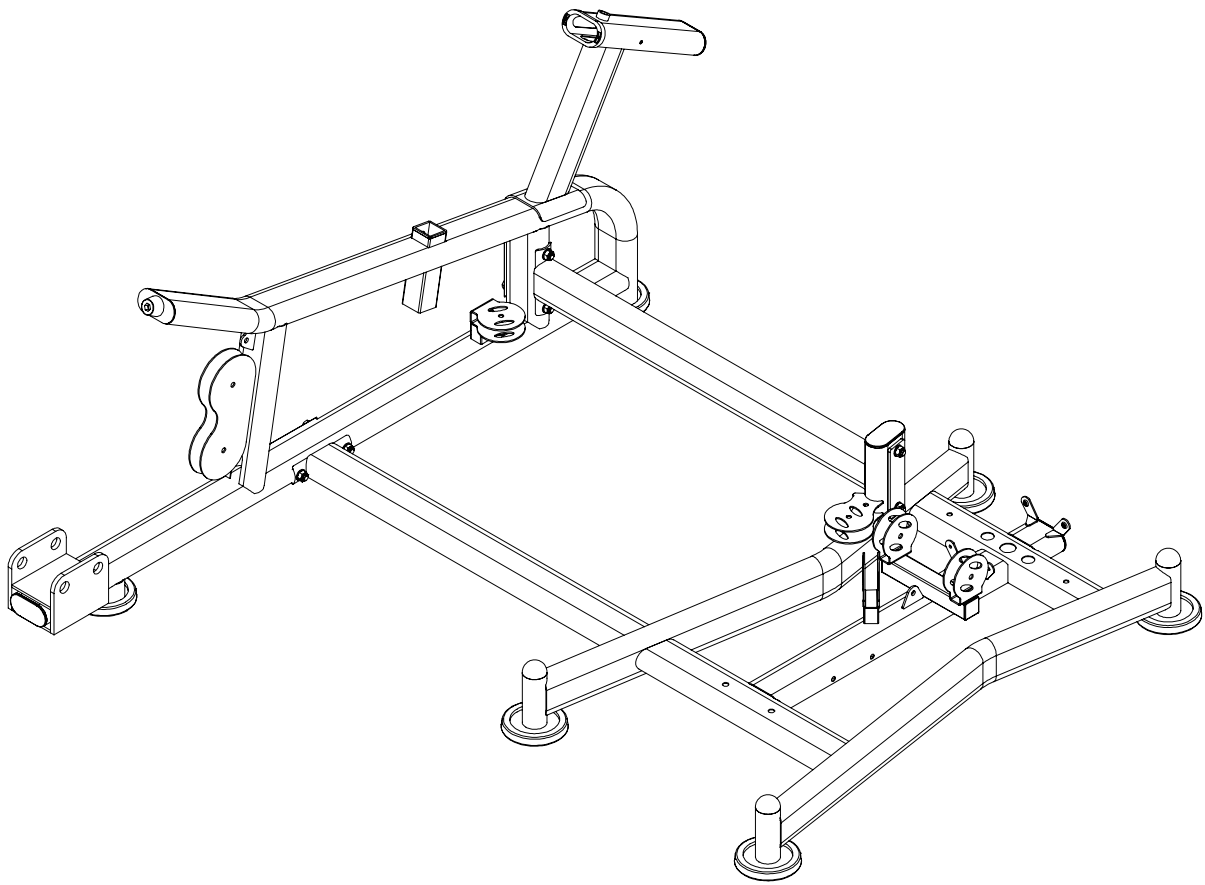

## Assembly step (1) assembly instruction

1. Fix leg press front connection tube(126) fastening on ground frame using: M12\*30 hexagon bolt(131), $\Phi$ 12 spring washer(130), $\Phi$ 12 washer(20)
2. Fix leg press back connection tube(127) fastening on ground frame using: M12\*80 hexagon bolt(132),  $\Phi$ 12 washer(20),M12 lock nut(21),connection plate(128)
3. Fix leg press main frame fastening on leg press front connection tube(126) using: M12\*125 hexagon bolt(133) , $\Phi$ 12 washer(20),M12 lock nut(21), arc-shaped connection plate(129)
4. Fix leg press main frame fastening on leg press back connection tube(127) using: M12\*125 hexagon bolt(133) , $\Phi$ 12 washer(20),M12 lock nut(21), arc-shaped connection plate(129)

**CAUTION: All bolts and pins should be tightening.**



## Assembly step (2) explosion drawing

No.	Description	Note	Qty.
134	leg press support tube-1		1
135	leg press support tube-2		1
136	shaft	Φ25*125	2
137	plug		4
138	hexagon socket button head bolt	M10*25	4

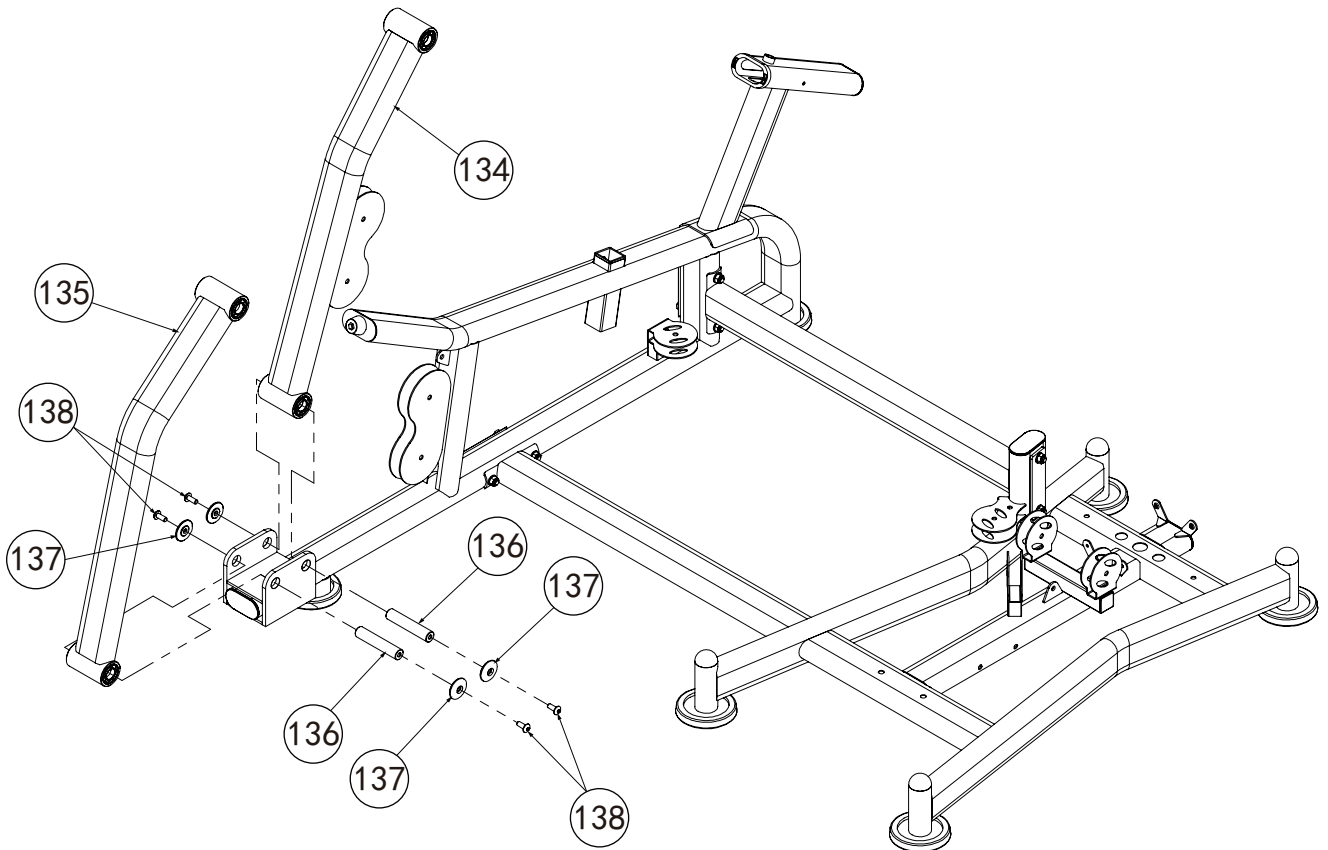

## Assembly step (2) drawing

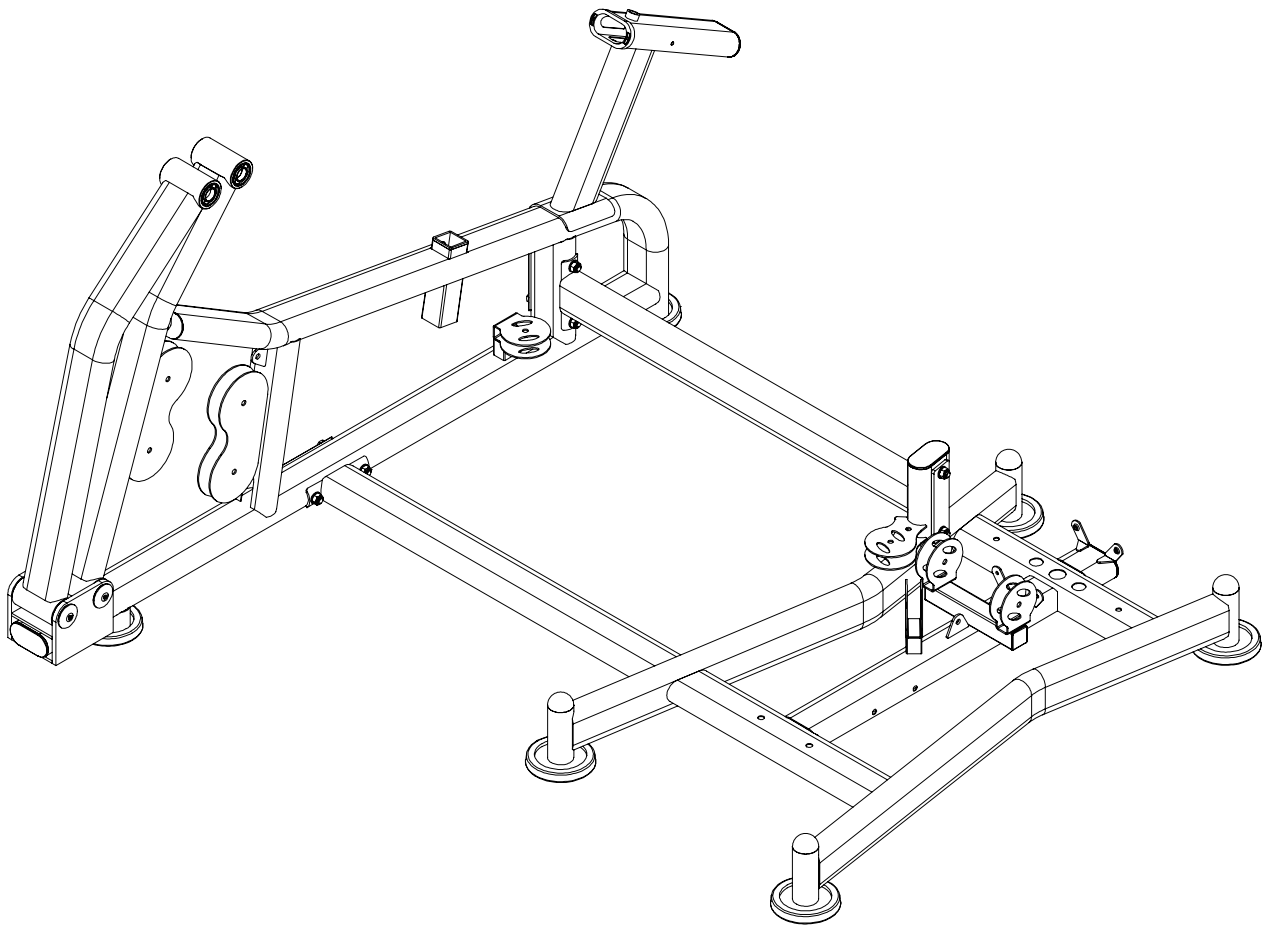

## Assembly step (2) assembly instruction

1. Fix leg press support tube-1(134) on leg press main frame using:  
 $\Phi 25 * 125$ shaft(136),plug(137),M10\*25 hexagon socket button head bolt (138)
2. Fix leg press support tube-2(135) on leg press main frame using:  
 $\Phi 25 * 125$ shaft(136),plug(137),M10\*25 hexagon socket button head bolt (138)

**CAUTION: All bolts should be tightening.**

## Assembly step (3) explosion drawing

No.	Description	Note	Qty.
23	lock nut	M10	2
35	big washer	Φ25*10*2.0	4
65	hexagon bolt	M10*75	2
137	plug		4
138	hexagon socket button head bolt	M10*25	4
139	shaft	Φ25*125	2
140	support tube		1
141	footplate tube		1

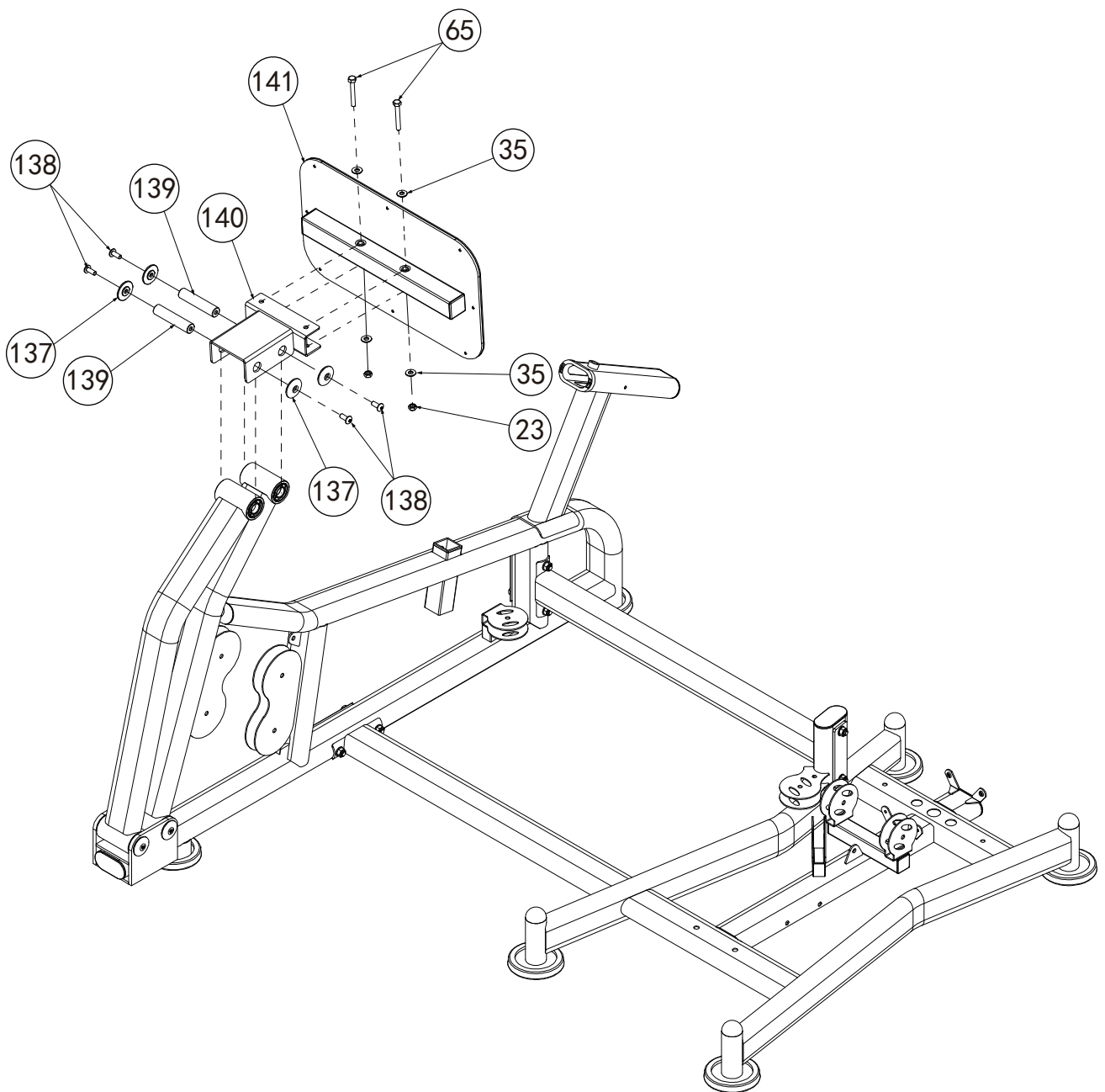

## Assembly step (3) drawing

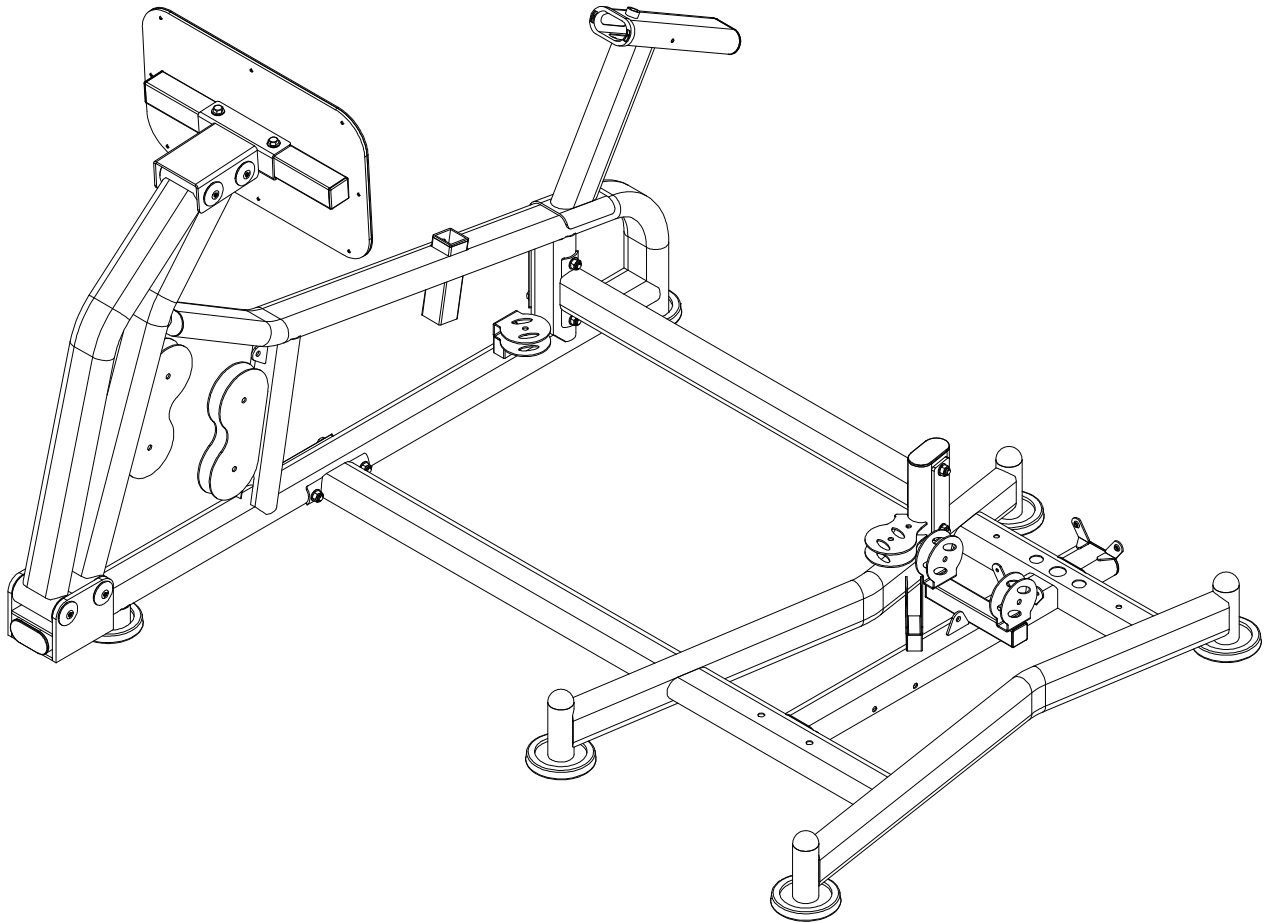

## Assembly step (3) assembly instruction

1. Fix leg press support tube-1 on support tube(140) using:  
Φ25\*115shaft(139),plug(137),M10\*25 hexagon socket button head bolt (138)
2. Fix leg press support tube-2 on support tube(140) using:  
Φ25\*115shaft(139),plug(137),M10\*25 hexagon socket button head bolt (138)
3. Fix footplate tube fastening on support tube(140) using:  
M10\*75 hexagon bolt(65),Φ10 big washer(35),M10 lock nut(23)

**CAUTION: All bolts should be tightening.**

# Assembly step (4) explosion drawing

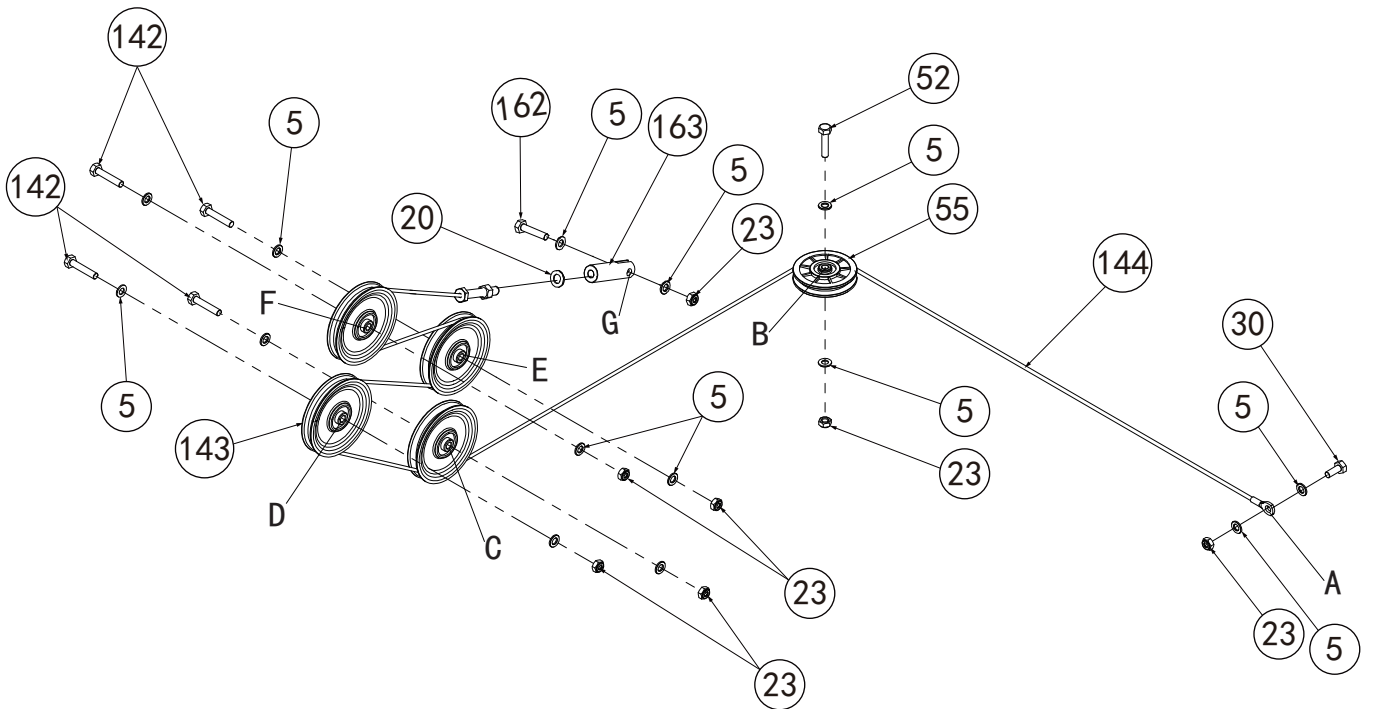
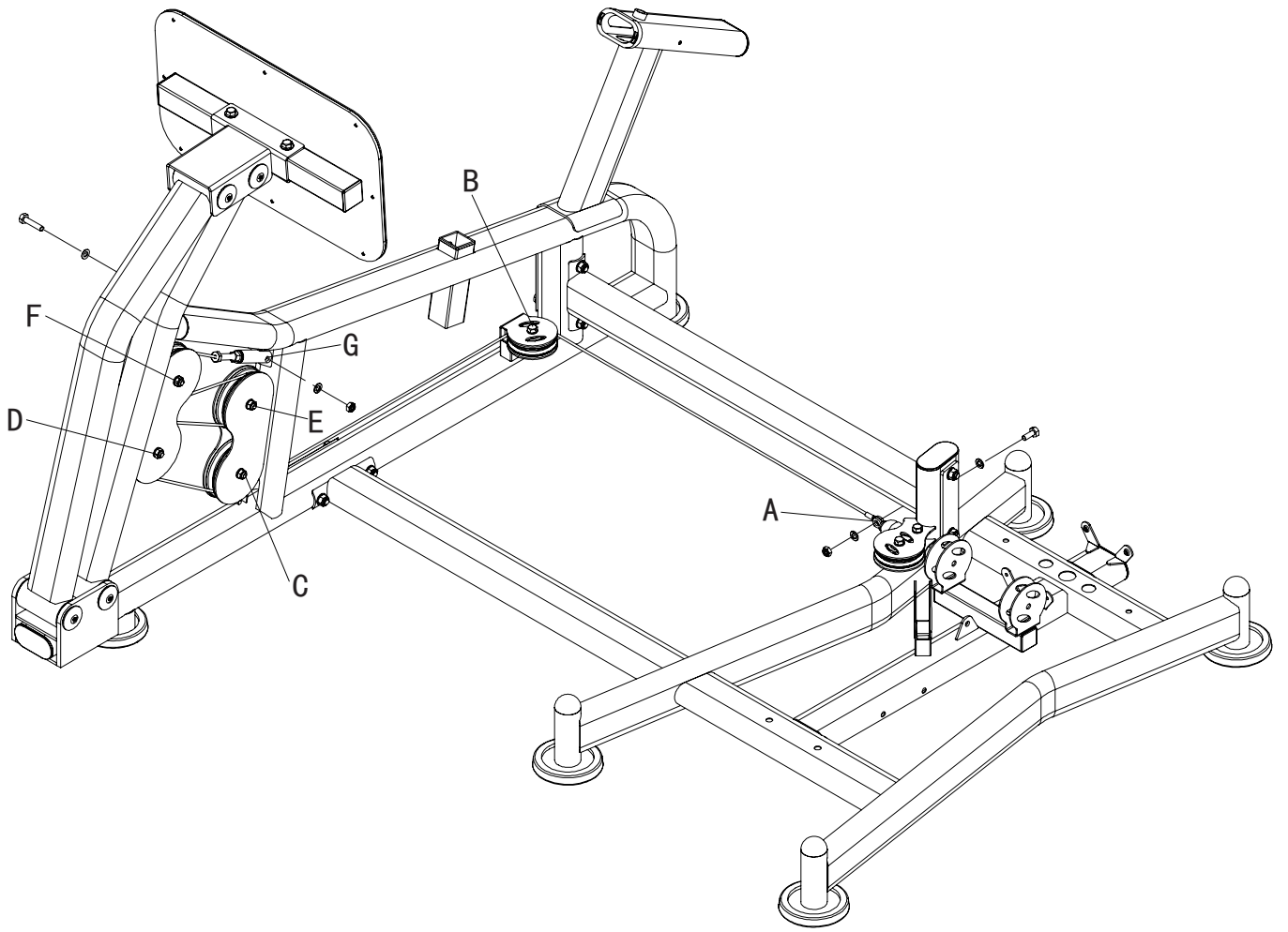

## Assembly step (4) cable drawing

No.	Description	Note	Qty.
5	washer	Φ10	14
20	washer	Φ12	6
23	lock nut	M10	7
30	hexagon bolt	M10*25	1
52	hexagon bolt	M10*45	1
55	pulley	Φ95*26	1
142	hexagon bolt	M10*50	4
143	big pulley	Φ127*28	4
144	leg press cable	L:3255mm	1
162	hexagon bolt	M10*40	1
163	cable adjust sleeve		1

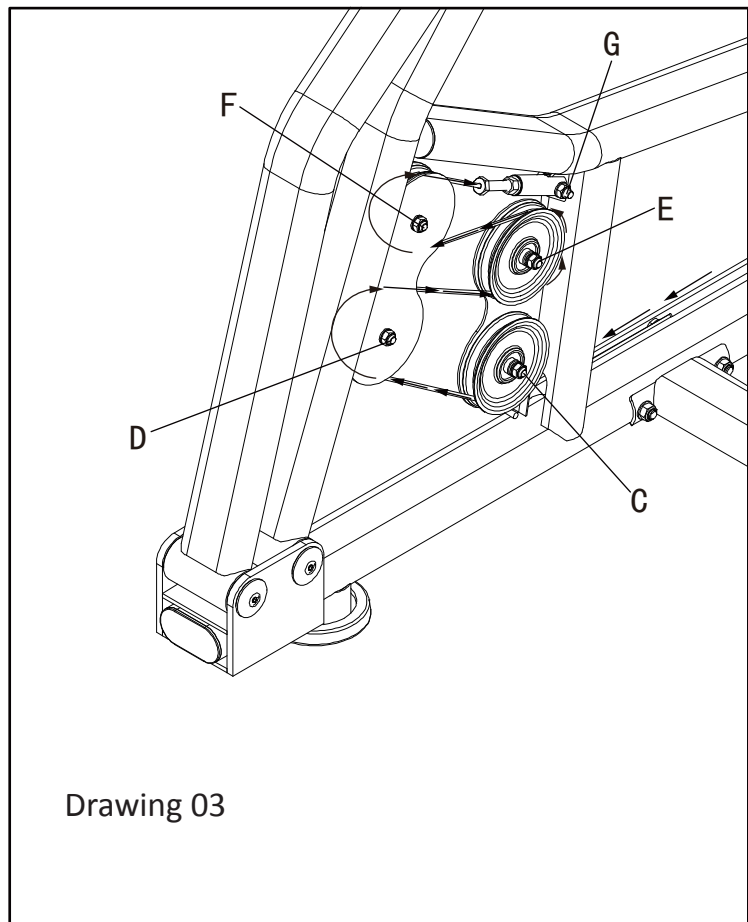
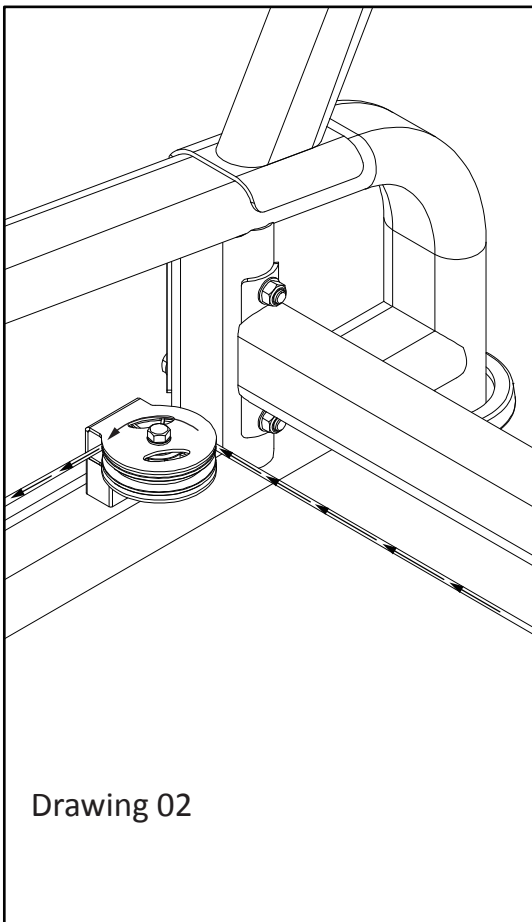
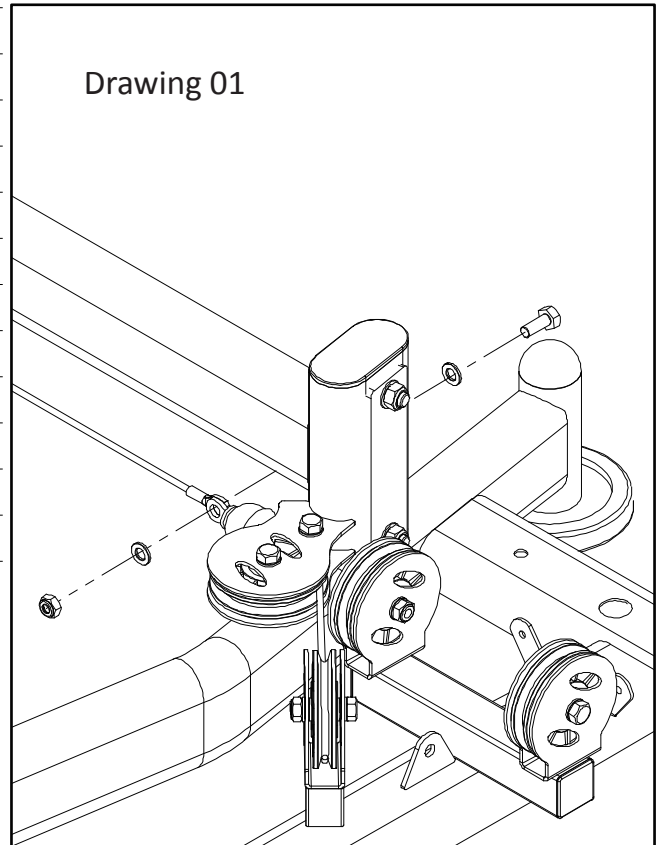

## Assembly step (4) drawing

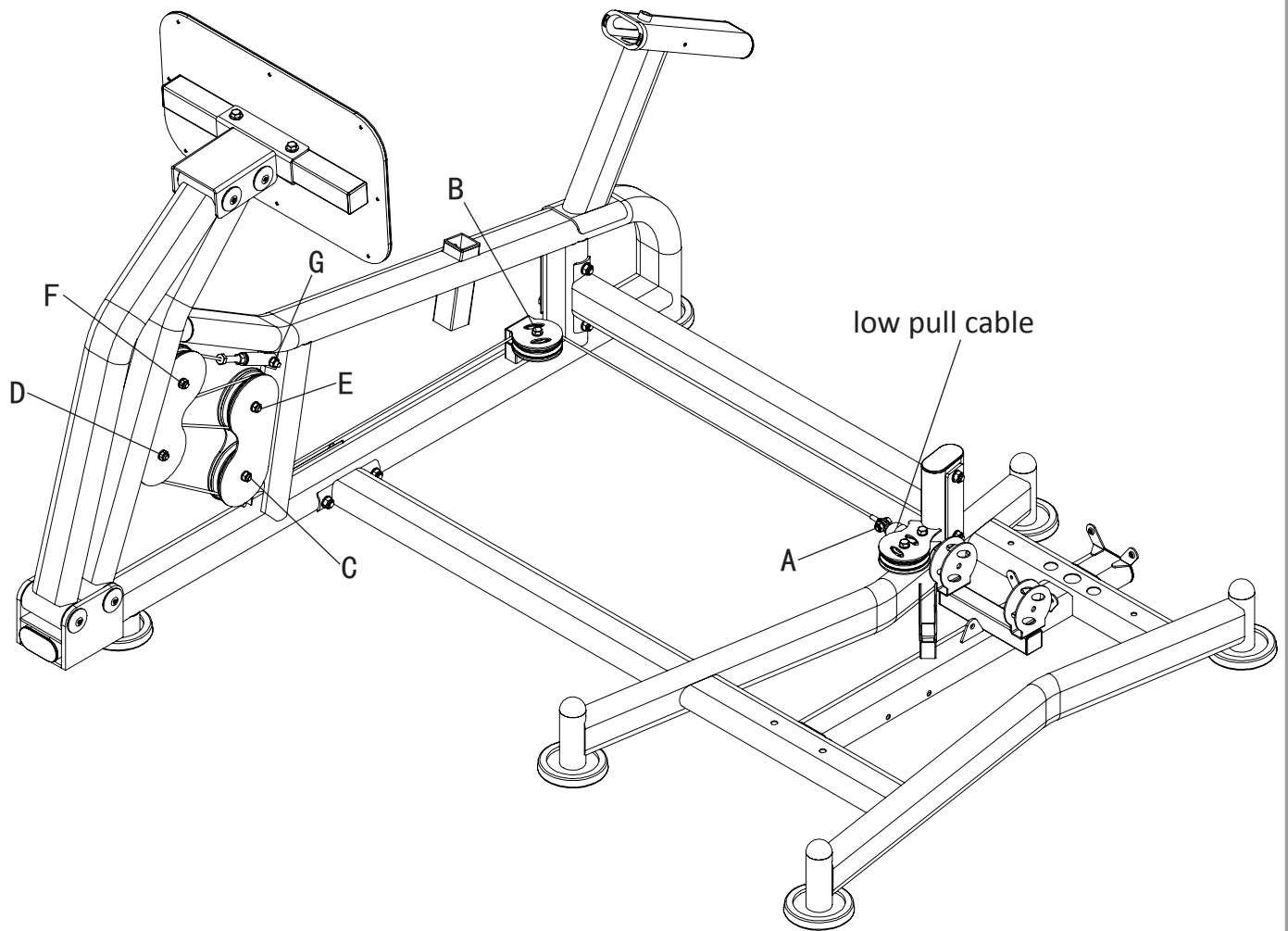

## Assembly step (4) assembly instruction

1. Fix leg press cable flat end fastening on low pull cable using:  
M10\*25 hexagon bolt(30), $\Phi$ 10 washer(5),M10 lock nut(23) as show in drawing 01
2. Leg press cable(144) thread end start through from point A in order B,C,D,E,F
3. Fix pulley(44) fastening on point B using:  
M10\*45 hexagon bolt(52), $\Phi$ 10 washer(5),M10 lock nut(23) as show in drawing 02
4. Fix big pulley(143) fastening on point C,D,E,F using:  
M10\*50 hexagon bolt(142), $\Phi$ 10 washer(5),M10 lock nut(23) as show in drawing 03
5. Connect leg press cable(144) flat end through  $\Phi$ 12 washer(20) with cable adjust sleeve(163)
6. Fix cable adjust sleeve(163) fastening on leg press main frame using:  
M10\*40 hexagon bolt(162), $\Phi$ 10 washer(5), M10 lock nut(23)

**CAUTION: All bolts should be tightening.**

## Assembly step (5) explosion drawing

No.	Description	Note	Qty.
11	lock nut	M8	2
15	washer	Φ8	8
18	locking spring knob	Φ10	1
72	spring washer	Φ8	4
145	hexagon bolt	M8*20	4
146	hexagon bolt	M8*70	2
147	leg press seat cushion adjust frame		1
148	leg press seat cushion		1
149	leg press handle		1

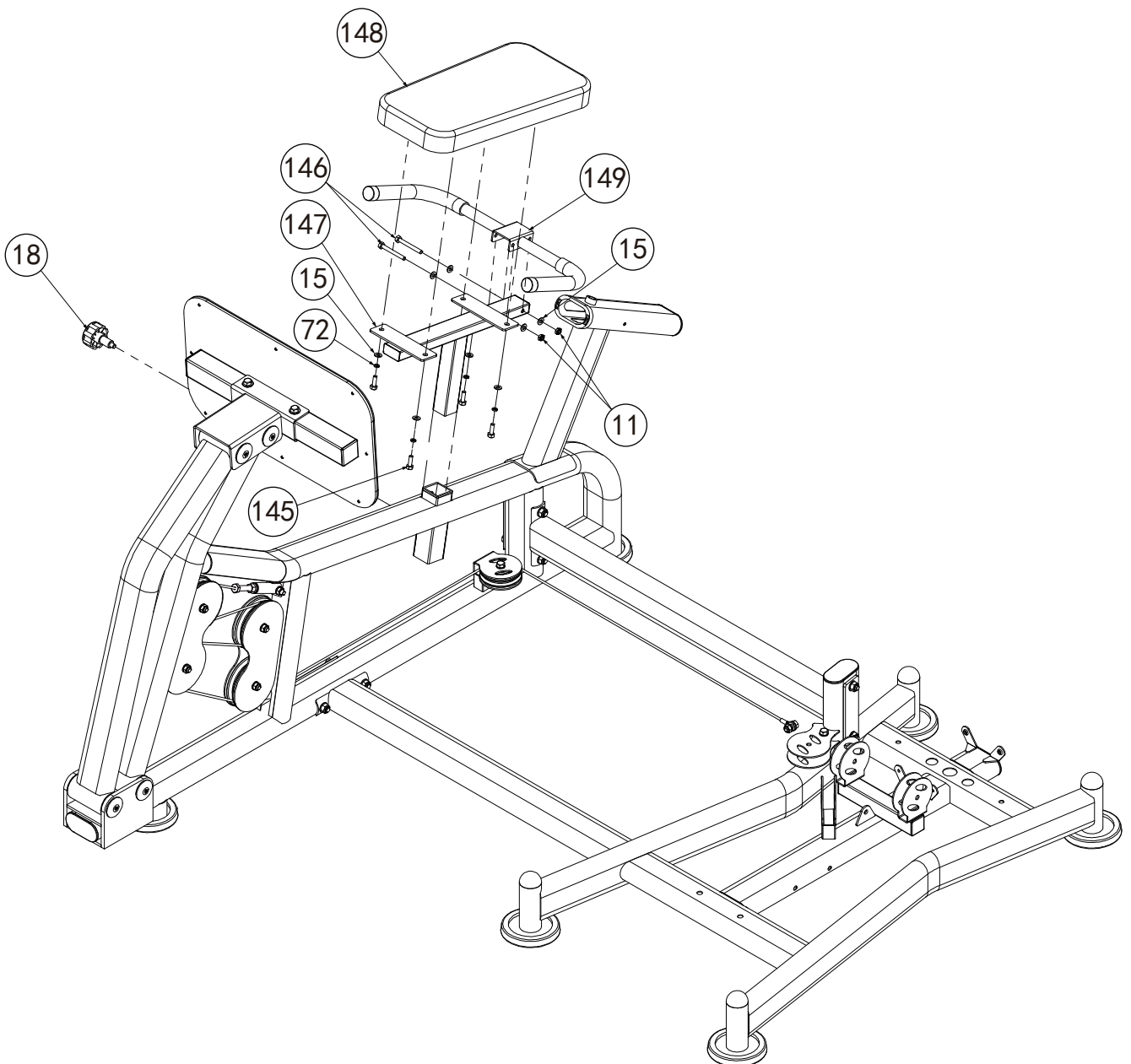



## Assembly step (5) drawing

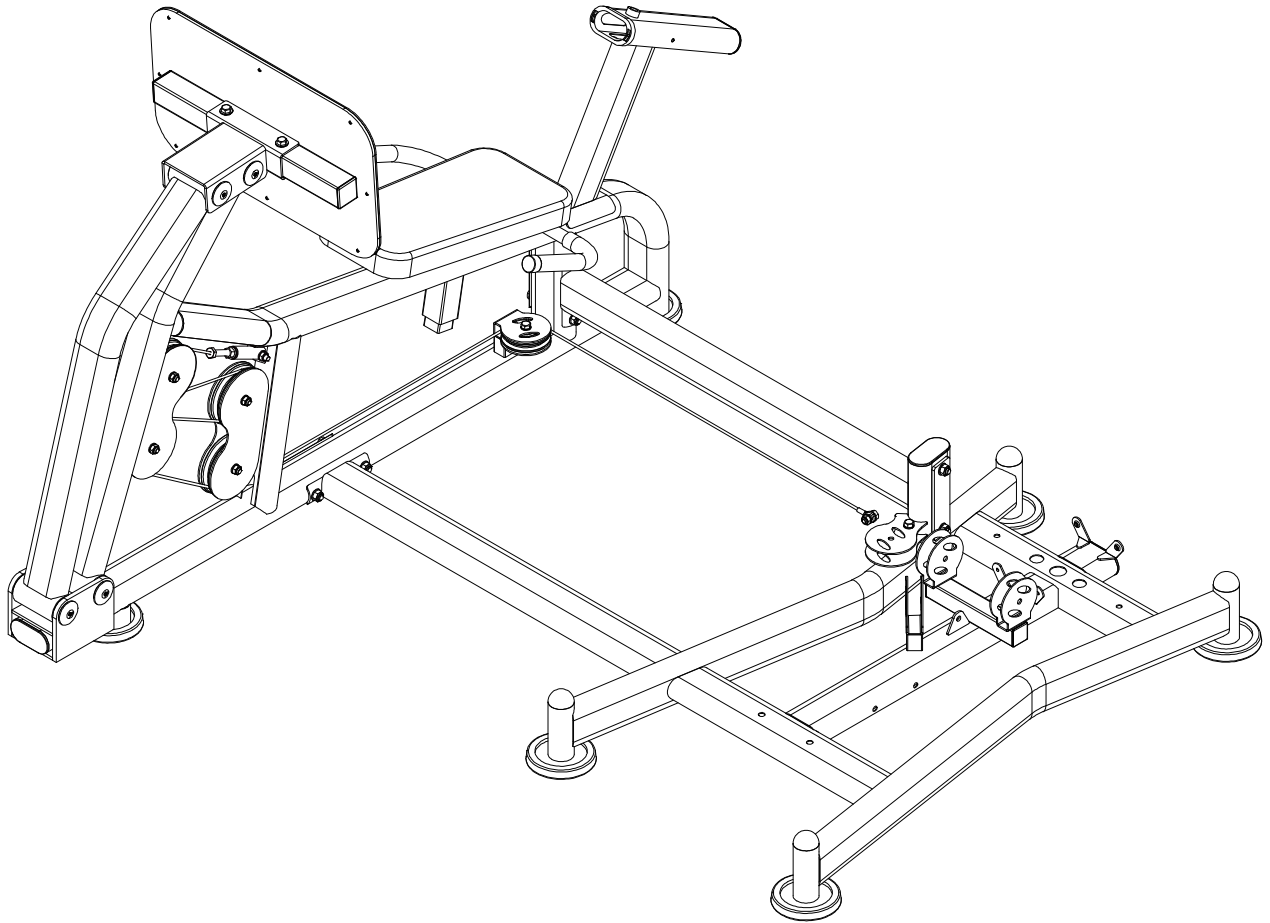

## Assembly step (5) assembly instruction

1. Fix leg press handle(149) fastening on leg press seat cushion adjust frame(147) using: M8\*70 hexagon bolt(146),  $\Phi$ 8 washer(15), M8 lock nut(11)
2. Fix leg press seat cushion(148) on leg press seat cushion adjust frame(147) using: M8\*20 hexagon bolt(145),  $\Phi$ 8 spring washer(72),  $\Phi$ 8 washer(15)
3. Slide leg press seat cushion adjust frame(147) to leg press main frame using locking spring knob(18)

**CAUTION: All bolts and pins should be tightening.**

## Assembly step (6) explosion drawing

No.	Description	Note	Qty.
15	washer	Φ8	5
18	locking spring knob	Φ10	1
72	spring washer	Φ8	4
145	hexagon bolt	M8*20	4
150	hexagon bolt	M8*25	1
151	leg press back cushion adjust frame		1
152	leg press back cushion		1

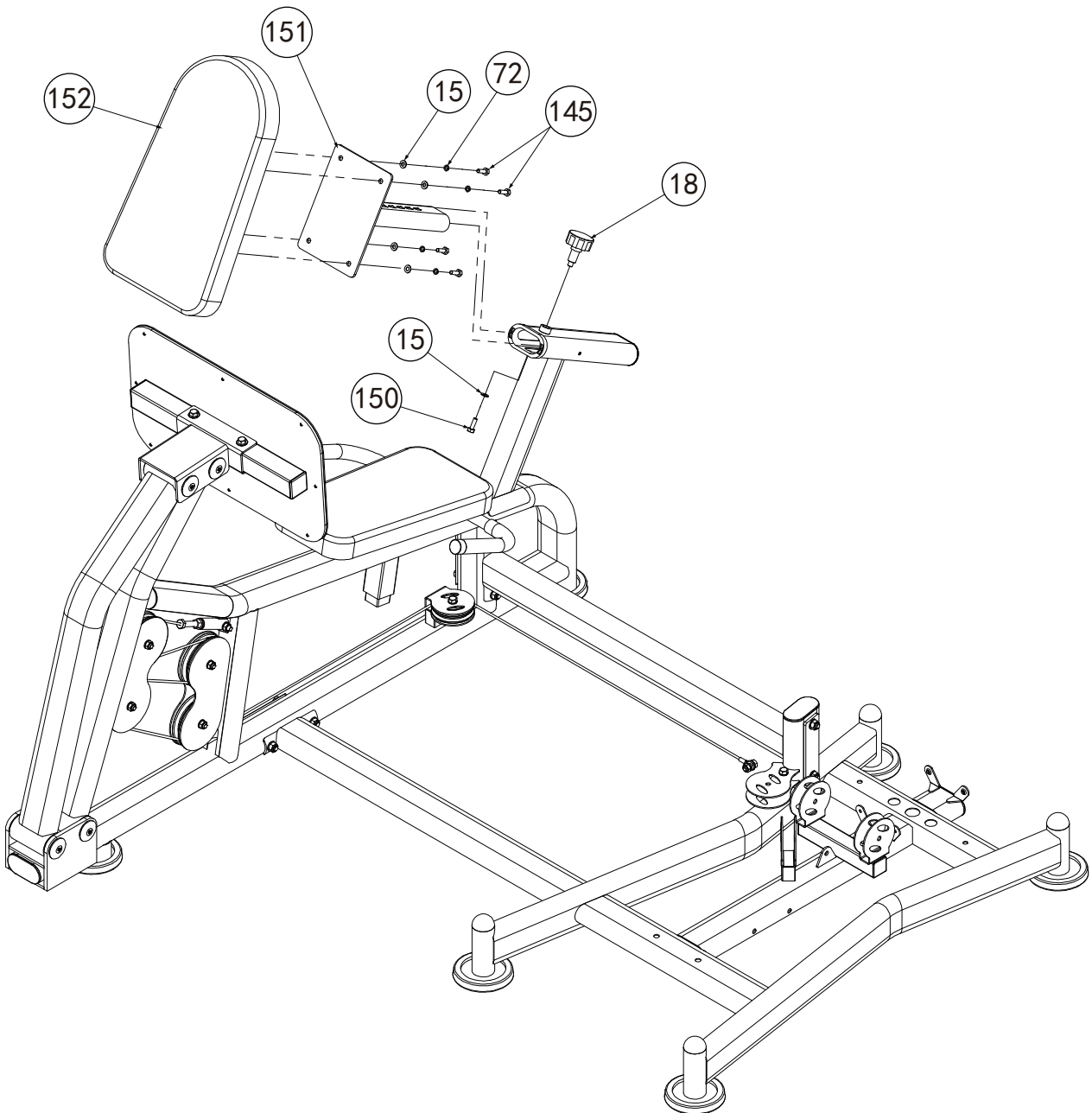

## Assembly step (6) drawing

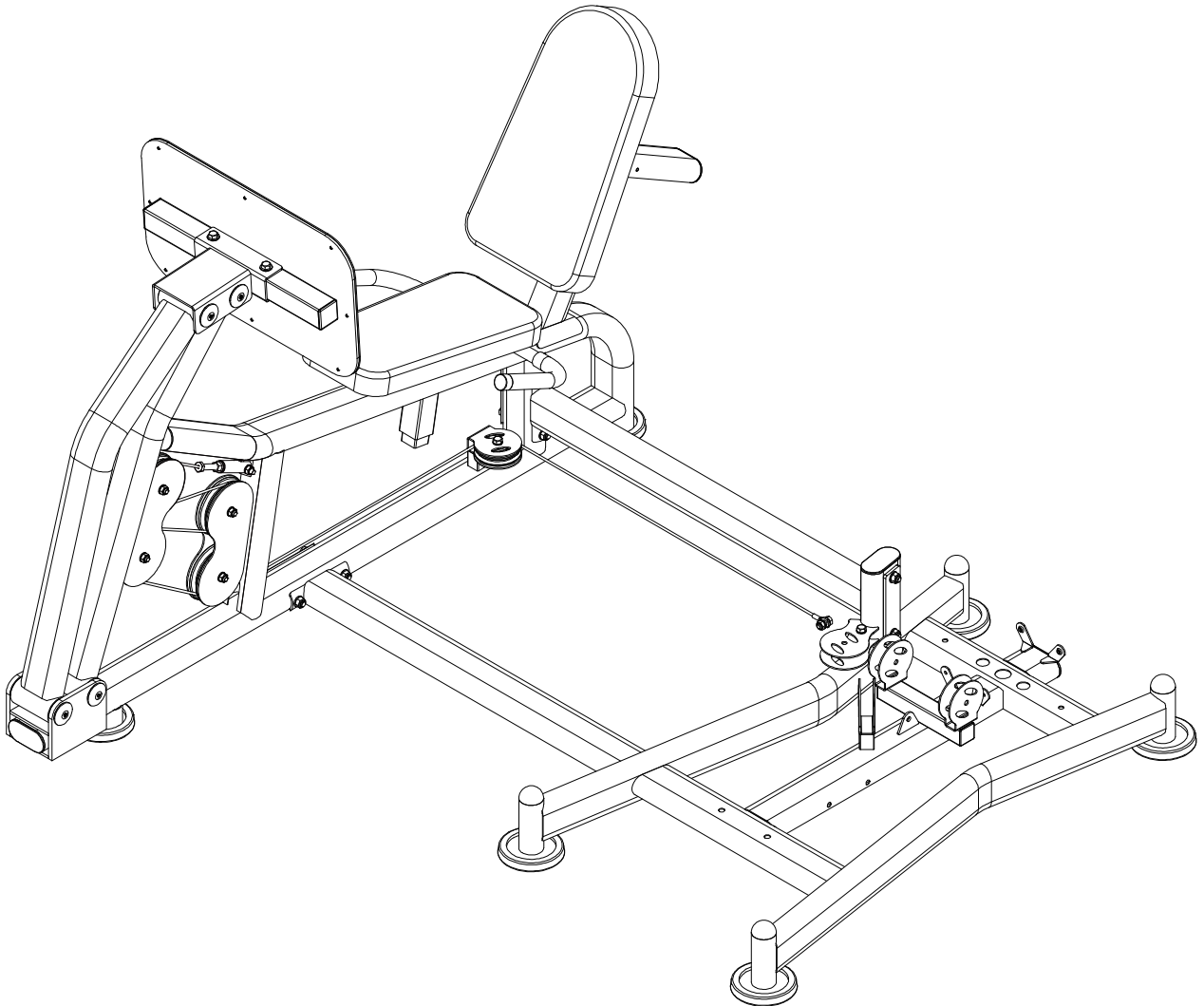

## Assembly step (6) assembly instruction

1. Fix leg press back cushion(152) on leg press back cushion adjust frame(151) using: M8\*20 hexagon bolt(145), $\Phi$ 8 spring washer(72), $\Phi$ 8 washer(15)
2. Slide leg press back cushion adjust frame(151) to leg press main frame using locking spring knob(18)
3. Fix M8\*25 hexagon bolt(150), $\Phi$ 8 washer(15) on leg press main frame

**CAUTION: All bolts and pins should be tightening.**

## Explosion drawing

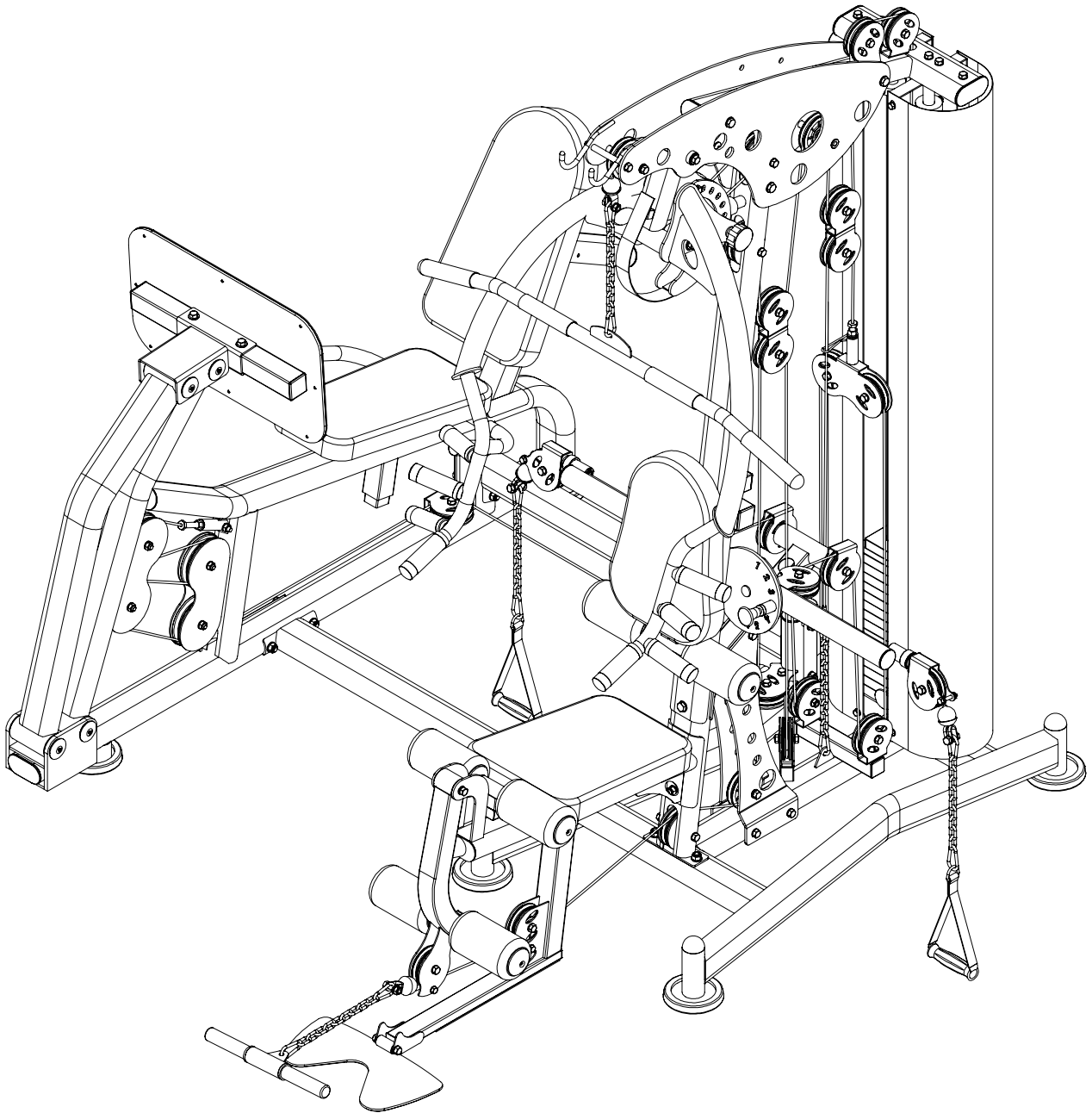

**CAUTION:** Please check machine all bolt, lock nut, pull pin whether tighten, tighten can use.

# Factory assembly drawing

No.	Description	Note	Qty.
89	foot margin cover	Φ120	2
92	oval tube plug	50-100	2
97	reduction sleeve	□50-40L	1
99	hexagon socket button head bolt	M8*16	1
153	oval reduction sleeve	50-100	1
154	cone rubber cushion	Φ42*Φ32*26	1

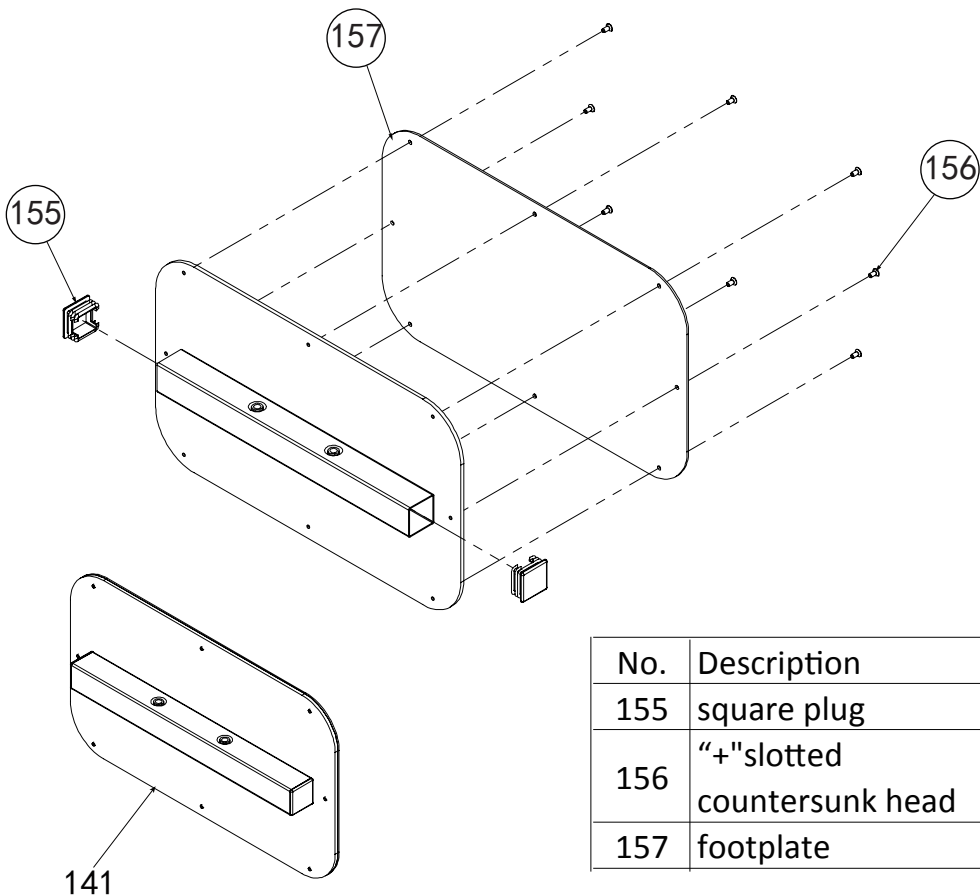
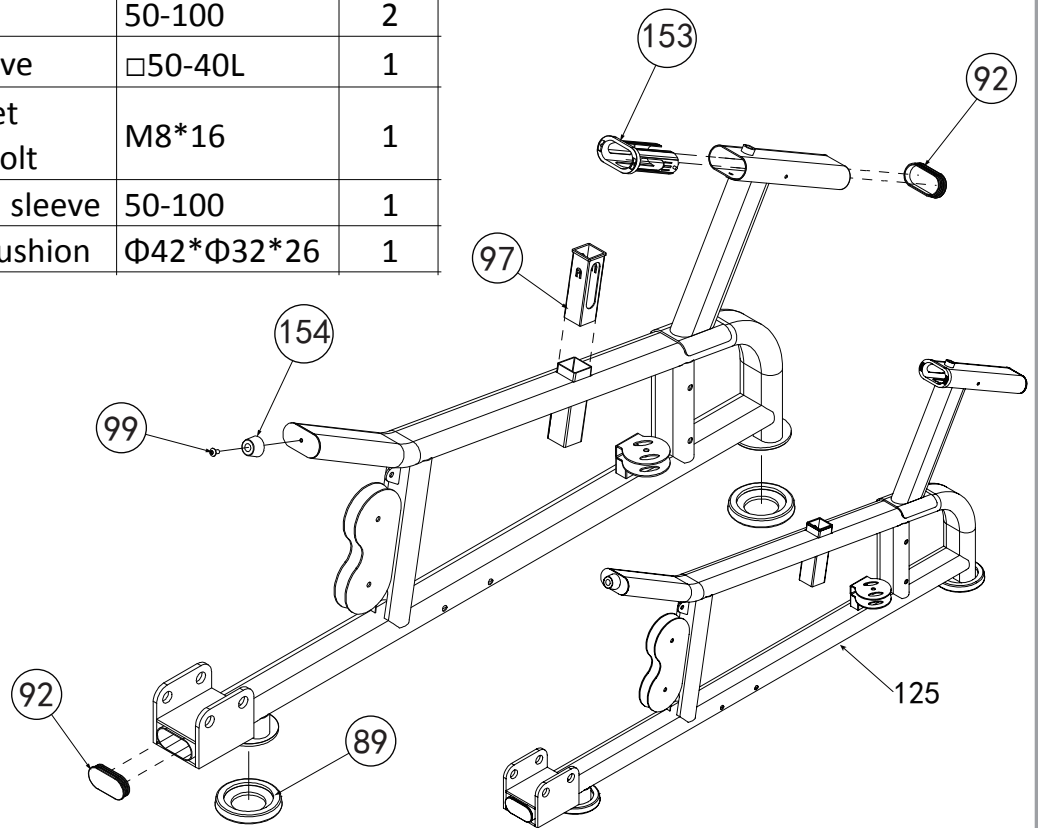

No.	Description	Note	Qty.
155	square plug	□50*50*2.0	2
156	"+"slotted countersunk head	M6*10	8
157	footplate		1

# Factory assembly drawing

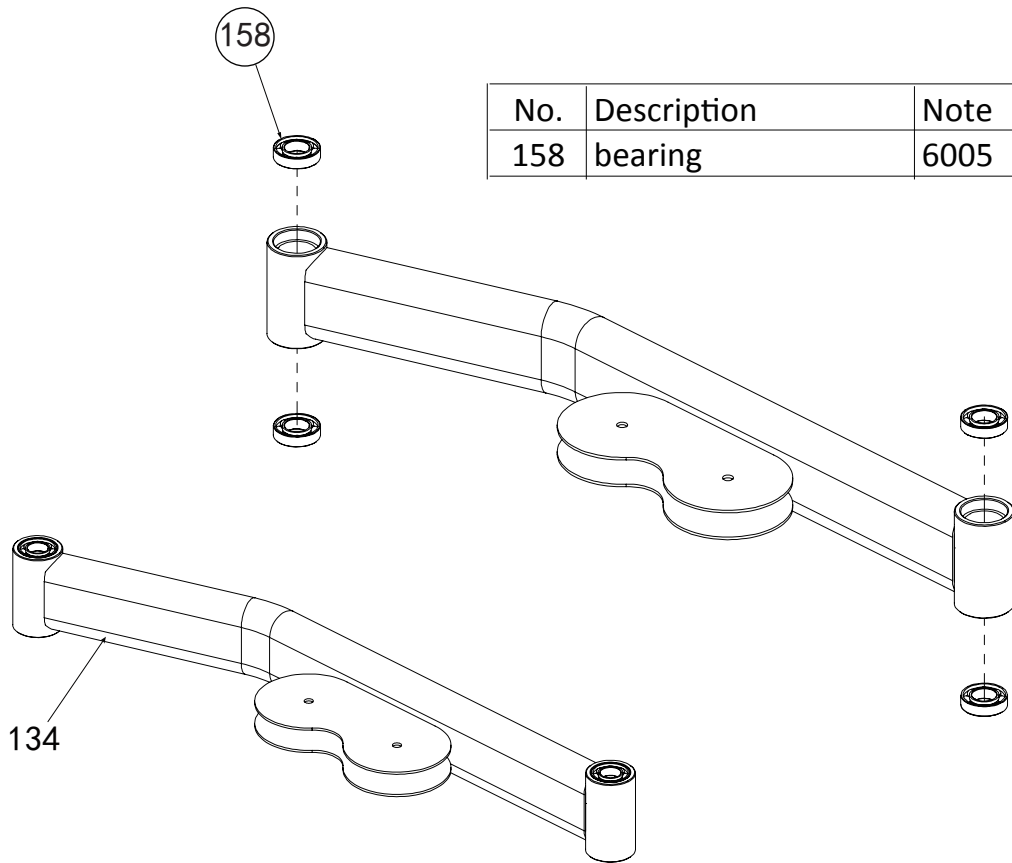

No.	Description	Note	Qty.
158	bearing	6005	4

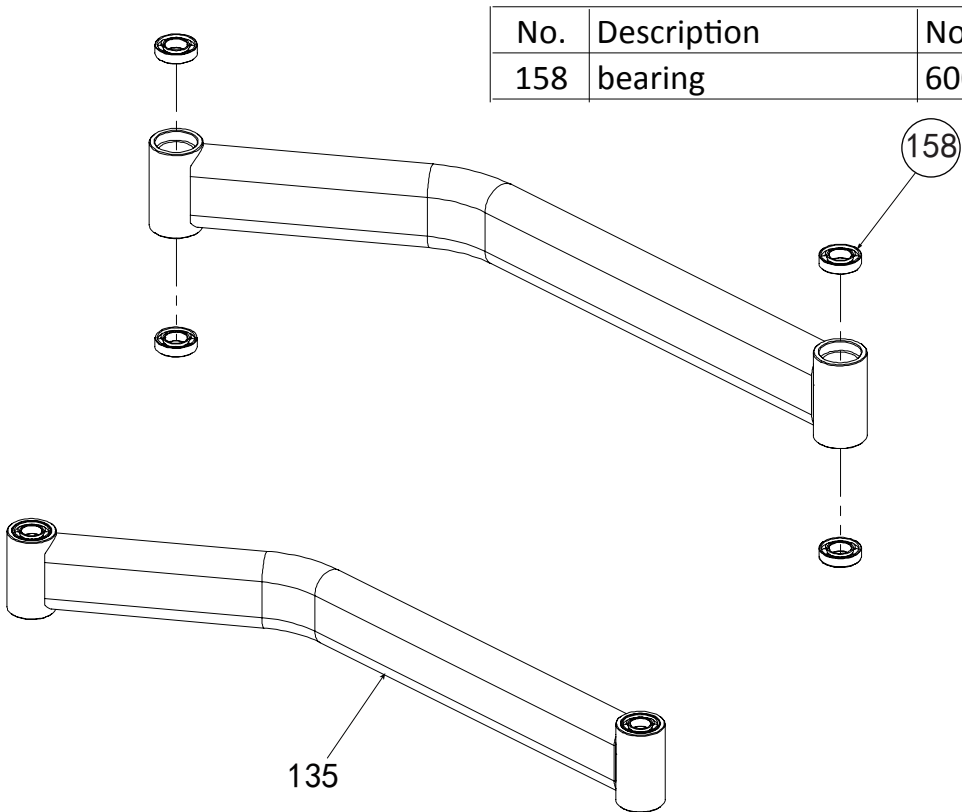

No.	Description	Note	Qty.
158	bearing	6005	4

# Factory assembly drawing

No.	Description	Note	Qty.
100	inner plug	□25*50	2

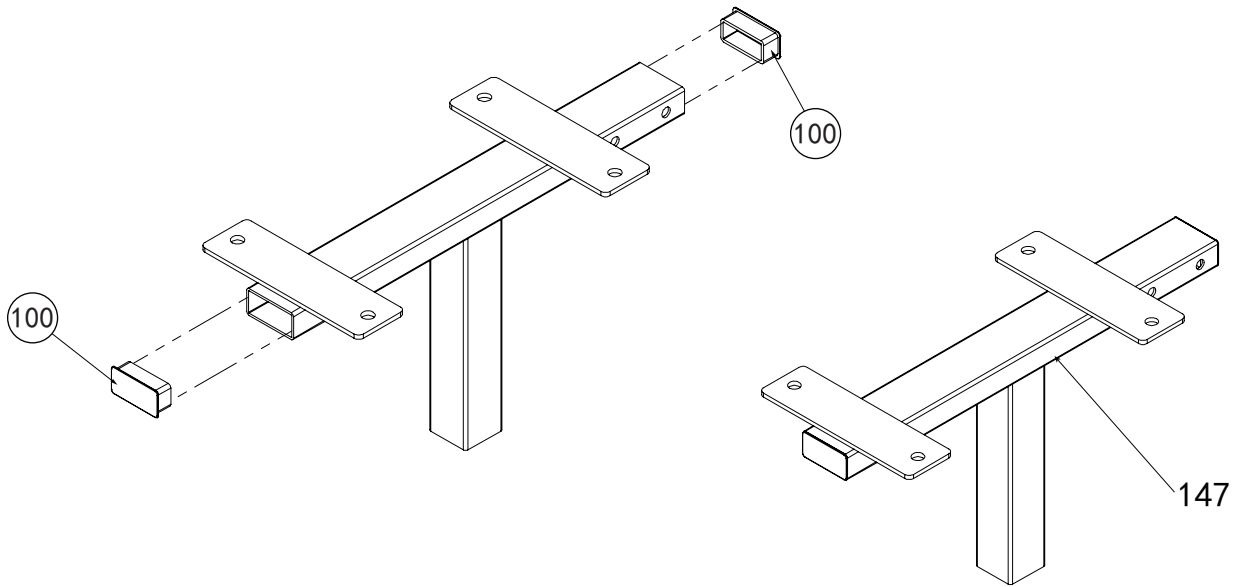

No.	Description	Note	Qty.
159	handle grip	Φ25	2
160	handle	Φ40*Φ25*29	2
161	"- "slotted headless bolt	M4*5	2

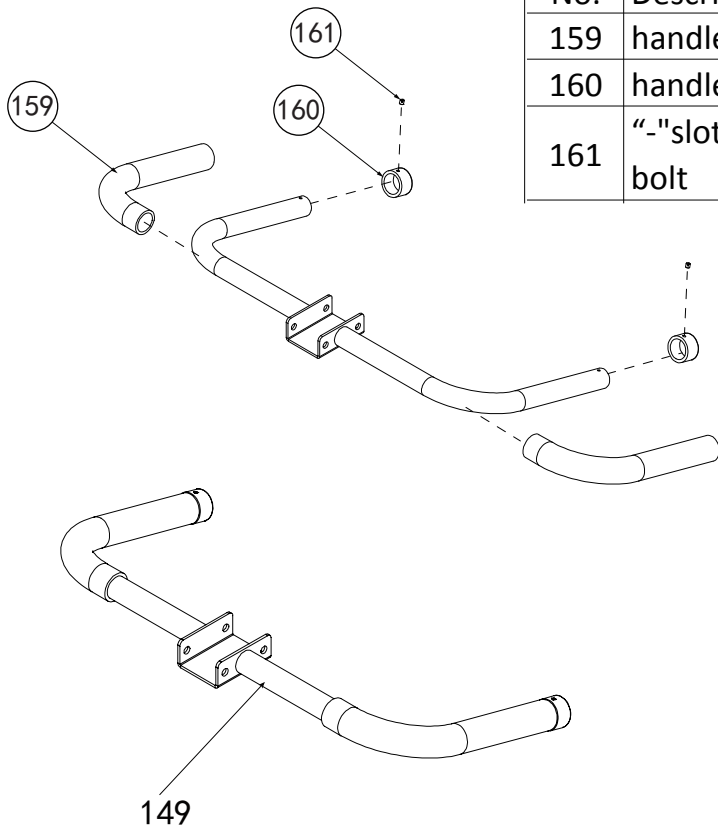



GARLANDO SPA  
Via Regione Piemonte, 32 - Zona Industriale D1  
15068 - Pozzolo Formigaro (AL) - Italy  
[www.toorx.it](http://www.toorx.it) - [info@toorx.it](mailto:info@toorx.it)